

TOX® Side Mount Tools

Side mount tools can be used for single and multiple points.

Advantages:

- space-saving mounting
- quicker and easier tool change
- tools can be exchanged individually

Side mount punch

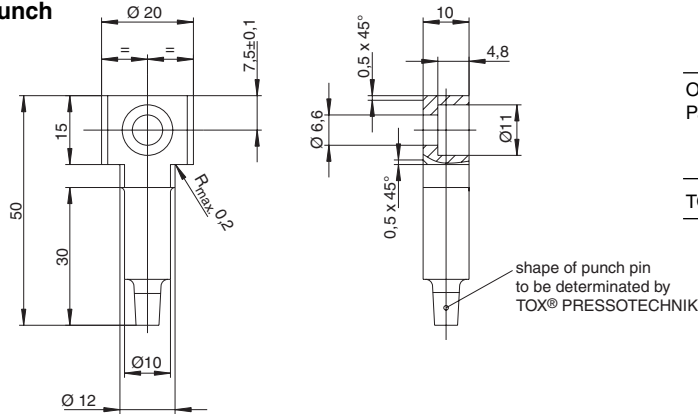

Order number Part 1 = design	for TOX® point Ø mm	Press force kN per point according to TOX® test report
TOX® 30.25	3 - 12	< 45

Dimensions in mm

Round joint side mount die (solid die cavity)

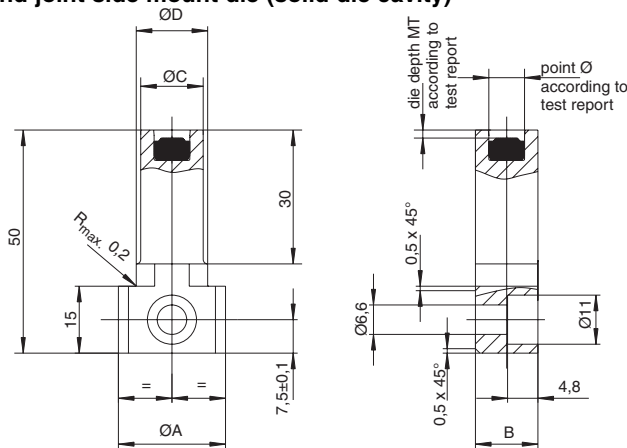

Order number Part 1 = design	A	B	C _{0,1}	D	for TOX®- point Ø mm	Press force kN per point according to TOX® test report
TOX® 30.25	20	10	10	12	3, 4, 5, (6)*	< 45
TOX® 31.25	24	14	14	16	6, 8	50
TOX® 32.25	26	16	16	18	10	55
TOX® 33.25	30	20	20	22	12	60

Dimensions in mm

* only after consulting TOX® PRESSOTECHNIK.

Die with insert features an integrated oil drainage system.

Type of installation in column-mounted die-set tool

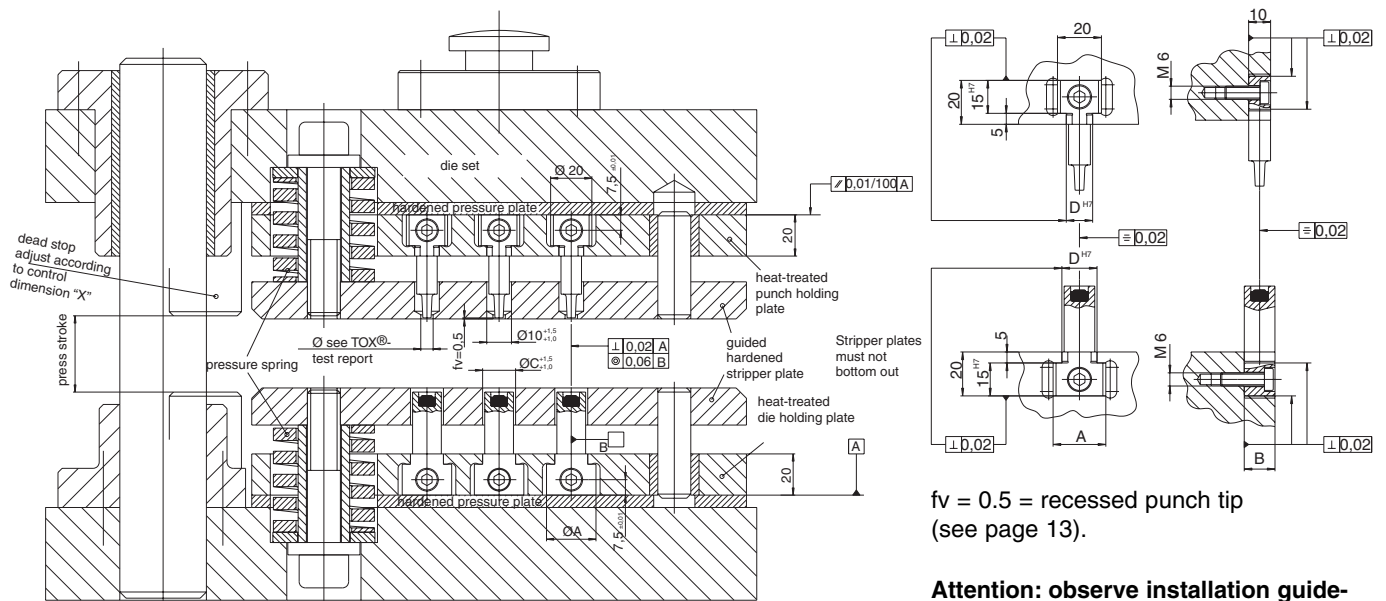

fv = 0.5 = recessed punch tip (see page 13).

Attention: observe installation guidelines and TOX® test report (see page 19 ff)